

4965 Kingston St. Denver CO 80239

www.falconrehab.com

ph. 800.370.6808 fax 800.faxphoton

BILL TO

Facility	PO#	Date
Address		
City	St	Zip
Phone	Fax	
Client Name	Client Code	
Completed by	Signature	

SHIP TO

Address		
City	St	Zip
Phone	Fax	

A

MEASUREMENTS (RECORD IN BOX BELOW)

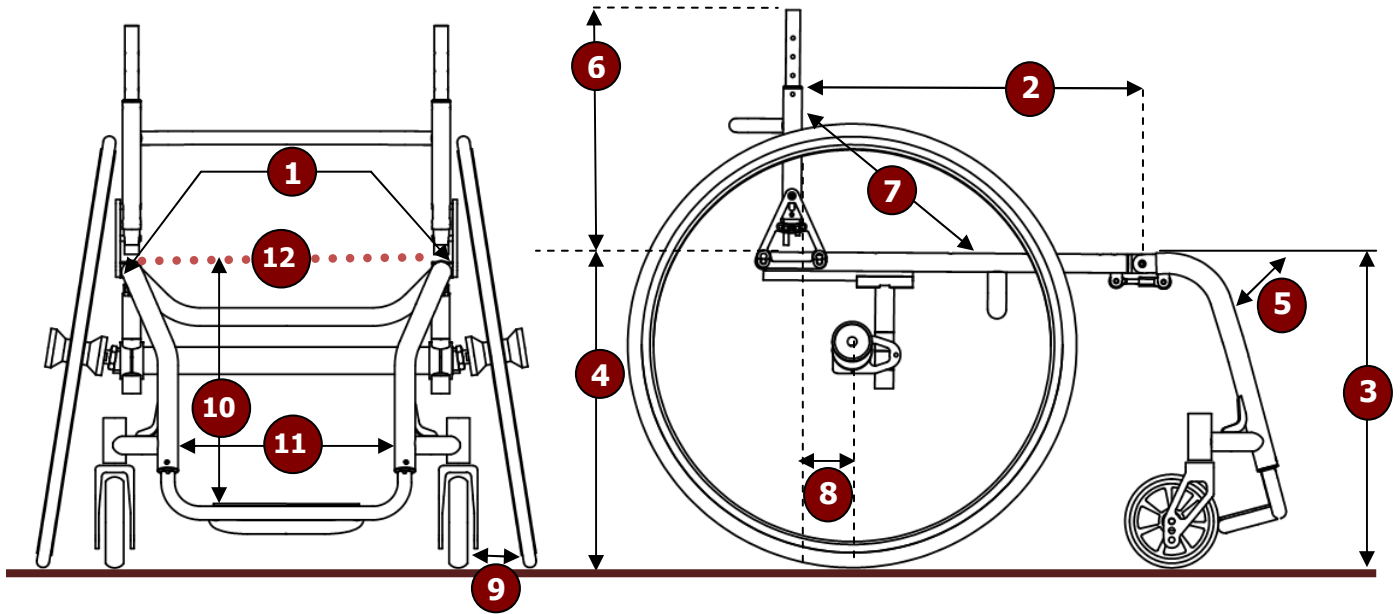

1. Measure from outside of seat tubes at back post
2. Measure inside of back post to front edge of seat upholstery
3. Measure from top of seat tube to floor
4. Measure from floor to top of seat tube at back post
5. Choose from front angle options provided
6. Measure from top of back post to top of seat tube at rear of frame
7. Measure angle from inside of back post to top of seat tube
8. Measure from front of back post at the seat tube to the center of

- the rear axle. There is **NO** need to order separate piece for amputee seating.
9. Choose from existing options on order form.
10. Measure from top of seat tube to footplate
11. Measure width of foot plate
12. Cushion height must be entered regardless of where you choose to obtain the cushion. .

1. Seat width	2. Seat depth	3. Front seat height	4. Rear seat height
5. Front frame angle	6. Seat back height	7. Back angle	8. Center of Gravity
9. Camber	10. Seat to footplate	11. Footplate width	12. Cushion Thickness

B

CONFIGURATION

BLADE 300 lb capacity –adj. center of gravity, rigid, lightweight frame with folding back

Width 16" 17" 18" 19" 20" 21" Custom*

Depth 16" 17" 18" 19" 20" 21" Custom*

Back Height Lo: (Adjusts 10" to 13") 10" 11" 12" 13"

Hi: (Adjusts 14" to 17") 14" 15" 16" 17"

Custom*

Front STF 18" 19" 20" 21" Custom*

Seat Dump Rear STF lower than Front STF by 0" 1" 2" 3" 4" Custom*

subtotal \$

WHEELS / TIRES

Camber 0° 3° 6° 9° Custom*

Caster Fork Standard Standard

Frog Legs™

Caster Wheels Solid 3" 4" 5" Standard

Rear Wheels 24" Lightweight Standard

24" Sun Rim w/steel spokes

24" Spinergy™

Custom*

Rear Tires High Pressure Pneumatic 1 3/8" wide Standard

Treaded 1 3/8" wide Knobby 2 1/4" wide

Custom*

Tubes Pneumatic

Airless Insert

Flat Free Liquid

Brakes Omit

Push to lock **High Mount only** Standard

Scissors Style

Handrims Aluminum Standard

Titanium

Natural Fit 24" Regular Grip Super Grip

subtotal \$

FRONT RIGGING

Standard

Angle 90 degree
 75 degree 85 degree

Front Squeeze (inside offset per side) 1" 1/1/2" 2"

subtotal \$

ANTI-TIPPERS

Omit
 Fixed Center Mount
 Quick Release

subtotal \$

ARMS / HANDLES

Omit
 Tubular swing-away







subtotal \$

UPHOLSTERY / GUARDS

Back Upholstery Omit
 Tension Adjustable
Clothing Guards Omit
 ABS

subtotal \$

COLORS

      Custom*

Metallic Purple Blue Black Yellow Metallic Green Red

subtotal \$

ACCESSORIES

Net bag
 Heel Loop
 Knee Protector (KPR)
 Gel tubular arm cover (pr.) (TAC)
 Gel leg wrap (pr) (LPW)
 Gel slip-on back cane cover
 Gel calf strap
 Foot Plate cover

subtotal \$

C**COMMENTS & SPECIAL REQUESTS**

--

D**COST**

Blade configuration	\$
Wheels/Tires	\$
Front Rigging	\$
Anti-tippers	\$
Arms/handles	\$
Upholstery/Guards	\$
Colors	\$
Accessories	\$
TOTAL	\$

E**Notes**

1. Custom items – please call customer service for actual quotation.